

Crosswise Convection Gas Convection Oven, 10 GN2/1

ITEM # _____

MODEL # _____

NAME # _____

SIS # _____

AIA # _____

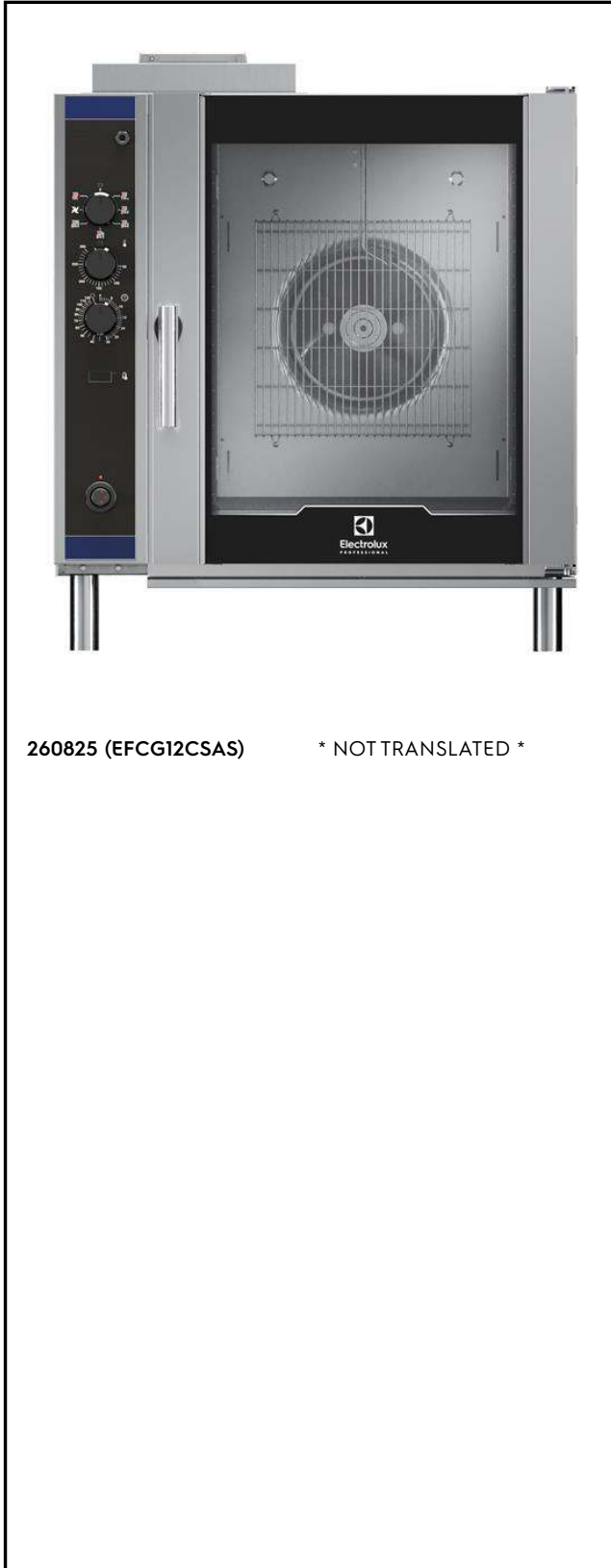

260825 (EFCG12CSAS)

* NOT TRANSLATED *

Main Features

- Main switch/Cooking mode selector which can be used to set: ON/OFF, hot air without humidification and hot air with humidification (choice of 5 different humidity levels).
- Rapid cooling of oven cavity.
- Timer to set the cooking time, adjustable up to 120 minutes or for continuous operation with an acoustic alarm to show the cycle has finished. At the end of the set cooking time the heat and the fan are automatically switched off.
- Maximum temperature of 300°C.
- Perfect evenness: guarantees perfect distribution of heat throughout the oven cavity.
- Halogen lighting and "crosswise" pan supports allow clear and unobstructed view of the products being cooked.
- Food temperature probe (available as accessory).
- Drip tray to collect residual cooking juices and fat.
- Drip tray under the door to collect condensed liquid available as accessory.
- Capacity: 10 GN 2/1 or 20 GN 1/1 trays.

Construction

- Robust structure thanks to stainless steel construction.
- Cooking chamber in 430 AISI stainless steel.
- Double thermo-glazed door with open frame construction, for cool outside door panel. Swing hinged easy-release inner glass on door for easy cleaning.
- Ergonomic door handle.
- Integrated drain outlet.
- 1 pair of 60 mm pitch runners is supplied as standard.
- IPx4 water protection.

Optional Accessories

- Pair of 1/1GN AISI 304 stainless steel grids PNC 921101
- Fat filter for gas 10 and 20 1/1 and 2/1 GN ovens (2 filters are necessary for 20-grid ovens) PNC 921700
- Flue condenser for gas ovens 10x1/1-2/1 PNC 921701
- Probe for ovens 10x2/1GN PNC 921703
- Guide kit for 1/1GN drain pan PNC 921713
- Pair of AISI 304 stainless steel grids, GN 1/1 PNC 922017
- Pair of grids for whole chicken (8 per grid - 1,2kg each), GN 1/1 PNC 922036
- AISI 304 stainless steel grid, GN 1/1 PNC 922062
- AISI 304 stainless steel grid, GN 2/1 PNC 922076
- Base for ovens 10x2/1GN PNC 922103
- Shelf guides for 10x2/1GN, oven base PNC 922107

APPROVAL: _____

- Feet for ovens 6x1/1GN, 10x1/1 and 2/1GN PNC 922127
- Retractable hose reel spray unit PNC 922170
- External side spray unit (needs to be mounted outside and includes support to be mounted on the oven) PNC 922171
- Pair of baking tray support PNC 922173
- Pair of AISI 304 stainless steel grids, GN 2/1 PNC 922175
- Fat filter for 10 1/1 and 2/1 GN combi steamers (gas and electric) and convection ovens (electric) PNC 922178
- Pair of frying baskets PNC 922239
- Grid for whole chicken (8 per grid - 1,2kg each), GN 1/1 PNC 922266
- Kit universal skewer rack and 6 short skewers for Lengthwise and Crosswise ovens PNC 922325
- Universal skewer rack PNC 922326
- 6 short skewers PNC 922328
- Smoker for lengthwise and crosswise oven (4 kinds of smoker wood chips are available on request) PNC 922338
- Mesh grilling grid PNC 922713
- Non-stick universal pan, GN 1/1, H=20mm PNC 925000
- Non-stick universal pan, GN 1/1, H=40mm PNC 925001
- Non-stick universal pan, GN 1/1, H=60mm PNC 925002
- Double-face griddle, one side ribbed and one side smooth, GN 1/1 PNC 925003
- Aluminum grill, GN 1/1 PNC 925004
- Frying pan for 8 eggs, pancakes, hamburgers, GN 1/1 PNC 925005

Front

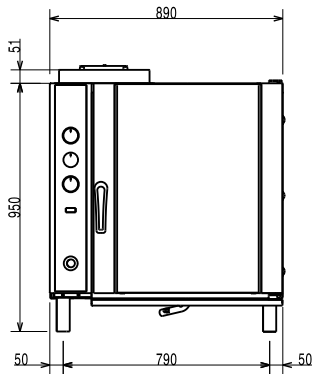

Side

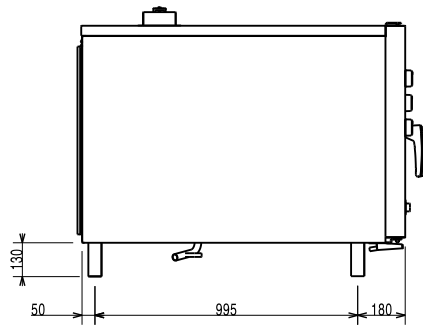

CW11 = Cold Water inlet 1 (cleaning) G = Gas connection
 CW12 = Cold Water Inlet 2 (steam generator)
 D = Drain
 EI = Electrical inlet (power)

Top

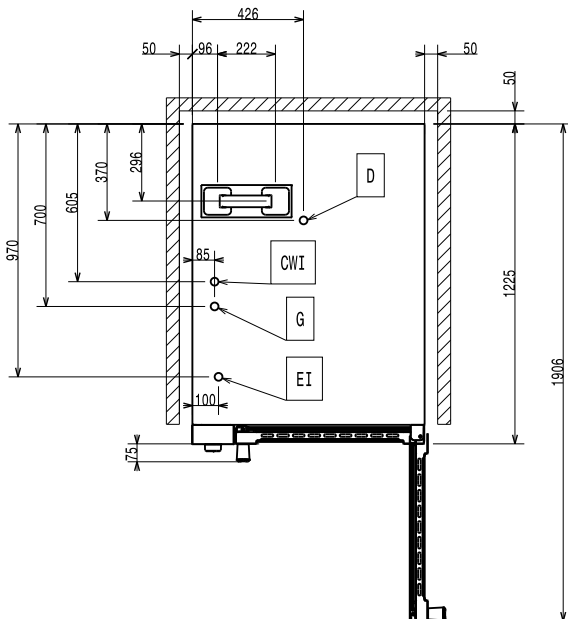

Electric

Supply voltage: 220-230 V/1 ph/50 Hz
Auxiliary: 0.5 kW
Electrical power max.: 0.5 kW

Gas

Gas Power: 25 kW

Capacity:

Trays type: 10 (GN 2/1)

Key Information:

External dimensions, Width: 890 mm

External dimensions, Depth: 1215 mm

External dimensions, Height: 970 mm

Net weight: 154 kg

Height adjustment: 80/0 mm

Functional level: Basic

Cooking cycles - air-convection: 300 °C

Crosswise Convection
Gas Convection Oven, 10 GN2/1

The company reserves the right to make modifications to the products without prior notice. All information correct at time of printing.